

# Differential pressure gauge

## Model 712.15.100, copper alloy

## Model 732.15.100, stainless steel version

WIKA data sheet PM 07.29



for further approvals  
see page 3

## Cryo Gauge

### Applications

- Level measurements in closed tanks, particularly in cryotechnology
- Filter monitoring
- Monitoring and control of pumps
- For gaseous and liquid media that are not highly viscous or crystallising and have no suspended solids

### Special features

- Differential pressure measuring ranges from 0 ... 40 mbar to 0 ... 1,725 mbar
- High working pressure (static pressure) of 50 bar
- Overpressure safety either side up to 50 bar
- Very compact design
- Optionally compact valve manifold with working pressure indication

### Description

These high-quality gauges are characterised by their compact and robust design and are primarily used for level measurement on liquid gas tanks.

With 11 different measuring cells all usual tank sizes in cryotechnology are covered. As a result of the large measuring range overlap of the respective measuring cells, the gauge installed on the tank can be adjusted to match a whole variety of gases such as Ar, O<sub>2</sub>, N<sub>2</sub> or CO<sub>2</sub>, with a full-scale deflection over a complete 270 degree sweep. The span adjustment is accessible from outside and does not affect the zero point. The mechanical display and the optional electrical output signal are calibrated simultaneously and easily.

An optional valve manifold for flange mounting with working pressure indication makes the central measurement of both level and working pressure possible in the one instrument.



**Fig. top: Differential pressure gauge model 712.15.100**

**Fig. centre: Option valve manifold with working pressure indication**

**Fig. bottom: Option adapter for flange mounting**

The level display can be supplied with an optional, integrated 4 ... 20 mA, 2-wire transmitter. Switch contacts for level and working pressure, as well as a transmitter for the working pressure can be retrofitted on site.

The standard centre distance of 37 mm between the process connections can be adapted to a custom centre distance of 31 mm or 54 mm using adapters for flange mounting.

## Design and operating principle

Pressures  $p_1$  and  $p_2$  act on the media chambers  $\oplus$  and  $\ominus$ , which are separated by an elastic diaphragm (1).

The differential pressure ( $\Delta p = p_1 - p_2$ ) leads to an axial deflection of the diaphragm against the measuring range spring (2).

The deflection, which is proportional to the differential pressure, is transmitted to the movement (5) in the indicating case (4) via a pressure-tight and low friction lever mechanism (3).

Overpressure safety is provided by metal bolsters (6) resting against the elastic diaphragm.

## Illustration of the principle

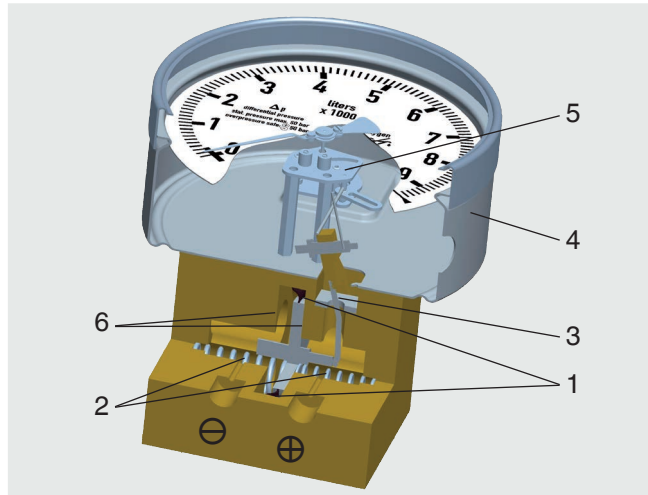

Mounting according to affixed symbols,  $\oplus$  high pressure and  $\ominus$  low pressure

## Standard version

Differential pressure gauge  
Model 712.15.100  
Model 732.15.100



## Specifications

<b>Nominal size</b>	NS 100 (level indication)
<b>Accuracy class</b>	2.5 (option: Class 1.6 or class 1.0)
<b>Scale ranges</b> (see also span adjustment)	<ul style="list-style-type: none"> <li>■ Measuring cell 60 mbar: Setting range 0 ... 40 mbar to 0 ... 60 mbar</li> <li>■ Measuring cell 90 mbar: Setting range 0 ... 60 mbar to 0 ... 90 mbar</li> <li>■ Measuring cell 120 mbar: Setting range 0 ... 80 mbar to 0 ... 120 mbar</li> <li>■ Measuring cell 165 mbar: Setting range 0 ... 110 mbar to 0 ... 165 mbar</li> <li>■ Measuring cell 240 mbar: Setting range 0 ... 160 mbar to 0 ... 240 mbar</li> <li>■ Measuring cell 330 mbar: Setting range 0 ... 220 mbar to 0 ... 330 mbar</li> <li>■ Measuring cell 480 mbar: Setting range 0 ... 320 mbar to 0 ... 480 mbar</li> <li>■ Measuring cell 660 mbar: Setting range 0 ... 440 mbar to 0 ... 660 mbar</li> <li>■ Measuring cell 975 mbar: Setting range 0 ... 650 mbar to 0 ... 975 mbar</li> <li>■ Measuring cell 1,350 mbar: Setting range 0 ... 900 mbar to 0 ... 1,350 mbar</li> <li>■ Measuring cell 1,725 mbar: Setting range 0 ... 1,150 mbar to 0 ... 1,725 mbar</li> </ul>
<b>Max. working pressure (static pressure)</b>	50 bar
<b>Overpressure safety</b>	either side up to 50 bar
<b>Permissible ambient temperatures</b>	-40 ... +80 °C, -40 ... +60 °C with oxygen
<b>Permissible medium temperatures</b>	-40 ... +80 °C, -40 ... +60 °C with oxygen
<b>Ingress protection</b>	IP 65 per EN 60529 / IEC 529
<b>Process connections (wetted)</b> Option with adapter	2 x G 1/4 (option: 2 x 1/4 NPT), female, lower mount (LM), centre distance 37 mm see page 5
<b>Measuring cell flanges (wetted)</b>	Model 712.15: Copper alloy CW614N (CuZn39Pb3) Model 732.15: Stainless steel 316L
<b>Pressure elements (wetted)</b>	Compression spring, stainless steel 1.4310 Separating diaphragm, NBR Transmission parts, stainless steel 1.4301 and 1.4305
<b>Movement</b>	Wear parts stainless steel
<b>Dial</b>	White aluminium (see section 'Scale designs')
<b>Pointer</b>	Adjustable pointer, black aluminium
<b>Zero adjustment</b>	By means of adjustable pointer
<b>Case / slip-on bezel</b>	Stainless steel, with clip fasteners
<b>Window</b>	Polycarbonate (PC)

## Span adjustment

The measuring span of the differential pressure gauge can, depending on the particular measuring cell used, be adjusted within the measuring range limits given in the previous specifications table. Ideally, this adjustment should be made on a test bench, though it can also be carried out at the measuring point using a hand test pump.

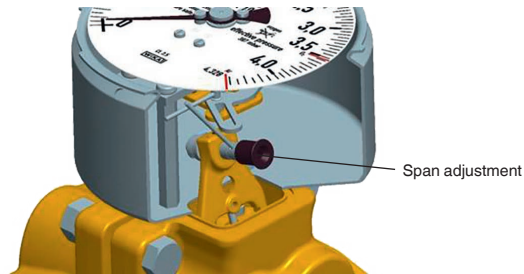

The span adjustment, situated at the 4 o'clock point on the case circumference, is accessible by removing the cover cap. With the gauge subject to the desired nominal

pressure, insert a hexagon screwdriver (SW 3 mm) into the funnel guide, and adjust the pointer to the final value by turning it clockwise (for a lower measuring range) or anti-clockwise (for a greater measuring range). The gauge will then be fully adjusted to the required measuring range. If the gauge is equipped with a transmitter model 89x.44, then this procedure will also adjust the output signal to the new measuring range. After completing the adjustment the instrument should be re-sealed with the cover cap.

## Scale designs

The dials can be made to customer's requirements and also with multiple scales. These can be printed with all usual units on them, e.g. kg, litre, m<sup>3</sup>, mmH<sub>2</sub>O, inchH<sub>2</sub>O, % etc.. Red marks for maximum fill level, customer logos and other custom printing are likewise possible. If desired, we can carry out the calculation for the tank fuel level from drawings of the tank geometry, and then make the appropriate scales.

## Dimensions in mm

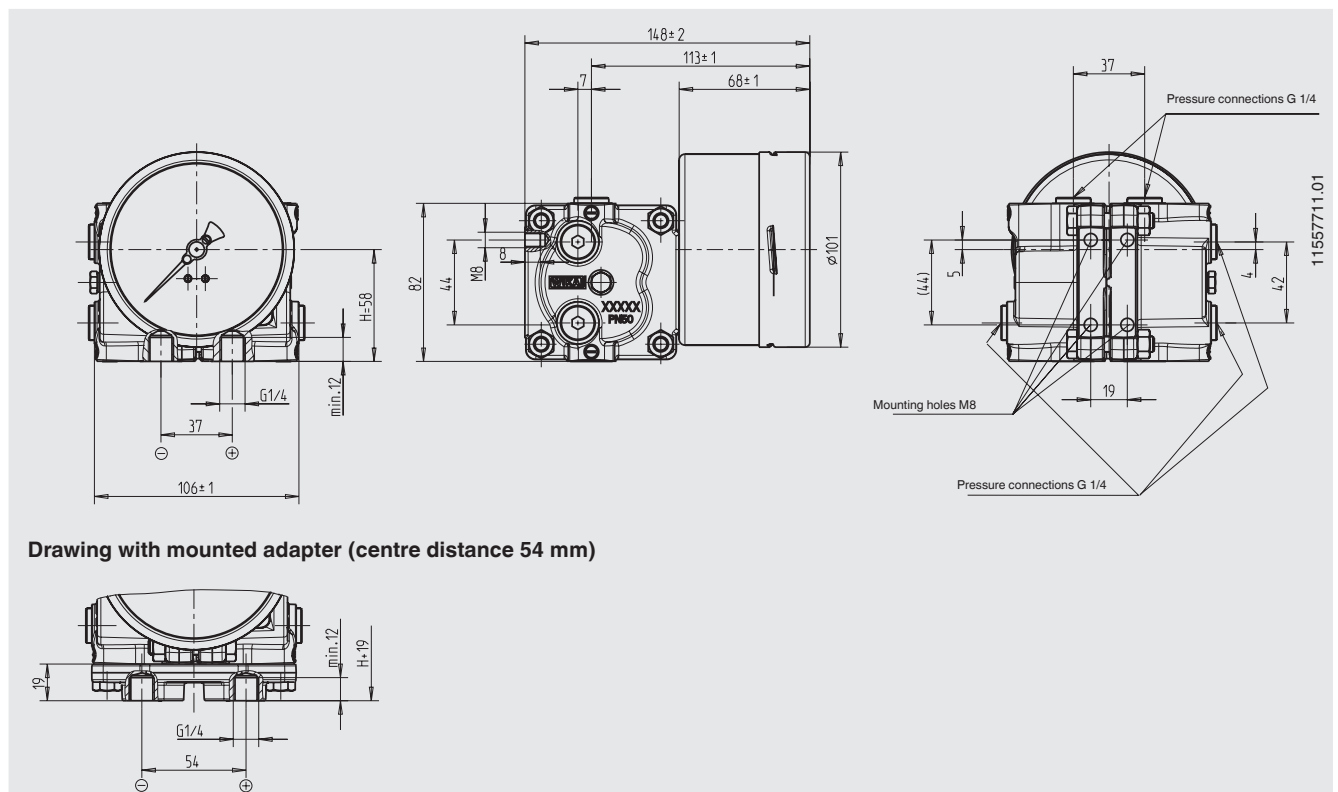

## CE conformity

### EMC directive

2004/108/EC, EN 61326 emission (group 1, class B) and interference immunity (industrial application)

### ATEX directive <sup>1)</sup>

94/9/EC, II 2 G Ex ia IIC

1) Option

## Approvals

- GOST, metrology/measurement technology, Russia
- GOST-R, import certificate, Russia
- CRN, safety (e.g. electr. safety, overpressure, ...), Canada
- CPA, metrology/measurement technology, China
- BAM, oxygen application (only for model 732.15)

Approvals and certificates, see website

## Option

Valve manifold (wetted)  
with mounted working pressure gauge

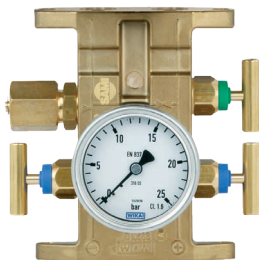

### Specifications

<b>Valves</b>	2 x shut-off valve, 1 x pressure equalising valve
<b>Test connection</b>	M20 x 1.5 with sealing cap (DIN 16287-A)
<b>Valve body</b>	Model 712.15: Copper alloy CW614N (CuZn39Pb3); model 732.15: Stainless steel 316L
<b>Spindle with conical nipple</b>	Model 712.15: Copper alloy; model 732.15: Stainless steel 316L
<b>Packing/sealing</b>	NBR/PTFE With the valve fully-opened, the spindle area is isolated from the process by a metallic seal, the packing is not loaded and the spindle thread is not in contact with the measured media.
<b>Working pressure gauge</b>	
<b>Standard</b>	Model 232.50.63, wetted parts stainless steel (for specifications and design details see data sheet PM 02.02)
<b>Option</b>	Model 212.20.100, wetted parts Cu-alloy (for specifications and design details see data sheet PM 02.01)

With a single order, all parts necessary for the fitting to the differential pressure gauge are included in the delivery: 4 x hexagon screws M8 x 16 , 2 x O-ring seal

### Dimensions in mm

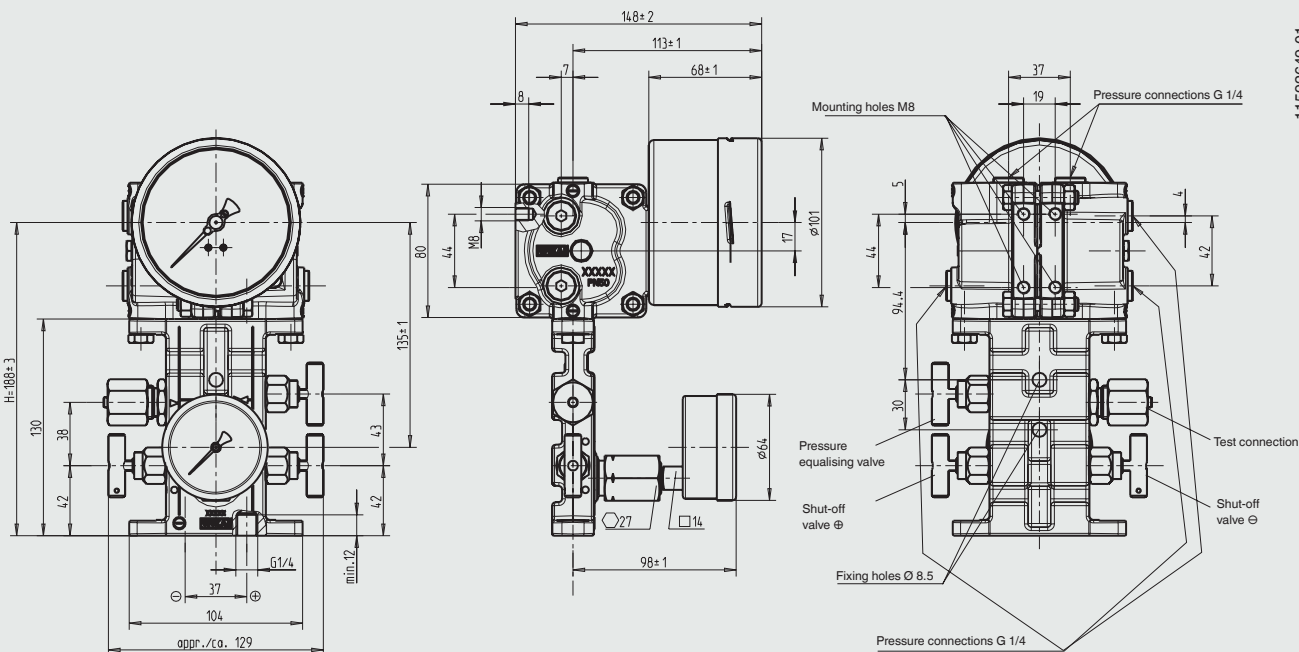

### Drawing with mounted adapter (centre distance 54 mm)

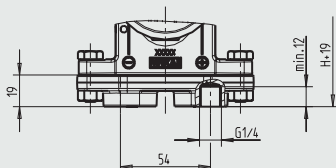

11592649.01

## Option

### Adapter for process connection



The adapters can be flange mounted either directly to the differential pressure gauge or to the valve manifold.

## Specifications

<b>Material</b>	Model 712.15: Cu-alloy CW614N (CuZn39Pb3); model 732.15: Stainless steel 316L
<b>Process connections (wetted)</b>	2 x G 1/4, female, lower mount (LM), centre distance 31 mm or 54 mm or 2 x 1/4 NPT, female, centre distance 31 mm or 54 mm

With a single order, all parts necessary for the fitting to the differential pressure gauge or to the valve manifold are included in the delivery:

2 x hexagon screws M8 x 16, 2 x hexagon screws M8 x 28, 2 x nut M8 and 2 x O-ring seal

## Option

### Transmitter for level indication

Standard version  
model 891.44  
Ex version model  
892.44

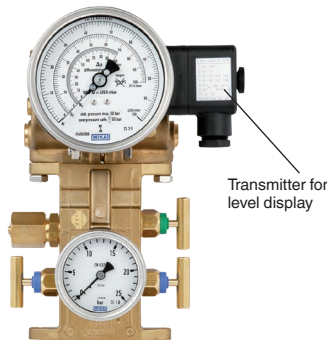

WIKA differential pressure gauges with an integrated model 89x.44 transmitter combine all the advantages of an on-site mechanical display with the demands modern industry makes for electrical signal transmission for the acquisition of measured values.

The transmitter is integrated into the case of the level display. The measurement span (electrical output signal) is set automatically by the mechanical display, i.e. the scale over a swept angle of 270 degrees corresponds to 4 ... 20 mA. With multiple scales (option) the output signal of 4 ... 20 mA corresponding to each, can be stored in a microprocessor. The output signal can be changed over to the desired fluid type by rotating the optional BCD switch (accessible through a cover cap on the left side of the case) using a screwdriver.

## Specifications

## Models 891.44 and 892.44 (Ex version)

<b>Supply voltage <math>U_B</math></b>	DC V	$12 < U_B \leq 30$ (min. 14 with Ex version)
<b>Influence of supply voltage</b>	% Full scale/10 V	$\leq 0.1$
<b>Permissible residual ripple</b>	% ss	$\leq 10$
<b>Output signal</b>		4 ... 20 mA, 2-wire
<b>Permissible max. load <math>R_A</math></b>		for non-Ex versions, model 891.44: $R_A \leq (U_B - 12 V) / 0.02 A$ with $R_A$ in $\Omega$ and $U_B$ in Volt for Ex versions, model 892.44: $R_A \leq (U_B - 14 V) / 0.02 A$ with $R_A$ in $\Omega$ and $U_B$ in Volt
<b>Effect of load</b>	% Full scale	$\leq 0.1$
<b>Adjustment</b>		
<b>Zero point, electrical</b>		Adjustment of the zero point through brief bridging of terminals 5 and 6 or using the 'scale selection switch' option, selectable via button <sup>1)</sup>
<b>Scale selection</b>		4 scales selectable via BCD switch
<b>Linearity</b>	% of span	$\leq 1.0$ % (terminal method)
<b>Permissible</b>		
<b>ambient temperatures</b>	°C	-40 ... +80, -40 ... +60 with oxygen
<b>Compensated temp. range</b>	°C	-40 ... +80
<b>Temperature coefficients in the compensated temp. range</b>		
Mean TK of zero	% of span / 10 K	$\leq 0.3$
Mean TC span	% of span / 10 K	$\leq 0.3$

1) Only possible within 30 seconds of connecting the voltage supply

## Further specifications

## Models 891.44 and 892.44 (Ex version)

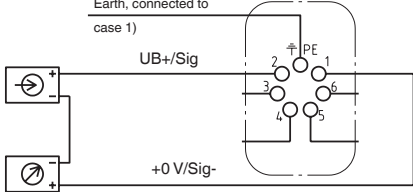
<b>Conformity specifications</b>		Ex version
■ Supply voltage $U_i$	DC V	14 ... max. 30
■ Short circuit current $I_i$	mA	max. 100
■ Power $P_i$	W	max. 1
■ Internal capacitance $C_i$	nF	12
■ Internal inductance $L_i$	mH	negligible
<b>Medium temperature</b>	°C	-40 ... +80, -40 ... +60 with oxygen
<b>Ambient temperature</b>	°C	-40 ... +60 (T6)
<b>Electrical connection</b>		Angular connector, 180° rotatable, wire protection, cable gland M20 x 1.5, incl. strain relief, connection cable: Outer diameter 7 ... 13 mm, conductor cross-section 0.14 ... 1.5 mm <sup>2</sup> , temperature resistance up to 60 °C
<b>Wiring protection</b>		Protection against reverse polarity and overvoltage
<b>Ingress protection</b>		IP 65 per EN 60529 / IEC 529
<b>Wiring details, 2-wire</b>		

## Option

### Transmitter for working pressure indication

Standard version model A-10  
or Ex version model IS-20

Transmitter for working pressure indication



The transmitters for the working pressure are screwed in sideways on the left side of the minus media chamber and can, if necessary, be retrofitted on site.

Pressure connection of the transmitter:  
G 1/4 (male)

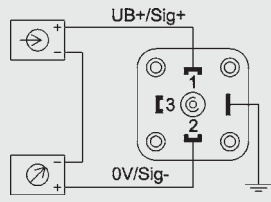
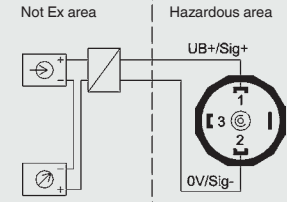

Specifications		A-10	IS-20
<b>Data sheet</b>		PE 81.60	PE 81.50
<b>Design</b>		standard	intrinsically safe
<b>Measuring ranges</b>	bar	0 ... 2.5 bis 0 ... 60	0 ... 2.5 bis 0 ... 60
<b>Outputs</b>	mA	4 ... 20	4 ... 20 (transmitter supply isolator)
<b>Medium temperature</b>	°C	-30 ... +100	-20 ... +80
<b>Ambient temperature</b>	°C	-30 ... +80	-20 ... +80
<b>Wetted parts</b>		Stainless steel	Stainless steel
<b>Supply voltage <math>UB</math></b>	DC	$10\text{ V} < UB \leq 30\text{ V}$	$10\text{ V} < UB \leq 30\text{ V}$
<b>Permissible max. load <math>RA</math></b>	Ohm	$RA \leq (UB - 8\text{ V}) / 0.02\text{ A}$	$RA \leq (UB - 10\text{ V}) / 0.02\text{ A}$
<b>Accuracy</b>			
Best Fit Straight Line, BFSL	% of span	$\leq 0.5$	$\leq 0.25$
<b>Compensated temperature range</b>	°C	0 ... 80 °C	0 ... 80 °C
<b>Designation of terminal connectors, 2-wire</b>			

## Option

### Switch contacts

for level and/or working pressure indicators

A modular system of electromechanical and electronic switch contacts with plug connection, also suitable for retrofitting on site, can be fitted both to the level display and to the working pressure indication. They consist of self-contained units, which can be fitted to any pointer pressure gauge within a few minutes. The connection to the instrument pointer is made by means of a special yoke so that a carrier pin at the pointer itself is not needed. The set value pointer of the installed switch contacts are adjusted, from the outside, to the value at which the switching operation is to take place, using the adjustment lock with a separate or integral key. A coupler connector, an M3 x 20 centring screw and a seal are included in the delivery.

Selectable are the following single and double contact models built into a self-contained unit

- Model 828 <sup>1)</sup>, magnetic snap-action contact
- Model 838 <sup>1)</sup>, inductive contact gauge

### Switching functions

The following applies, as a general rule, to the contact functions of the model 828 <sup>1)</sup> in connection with our standard settings:

**Index 1** according to the contact type no. means:

**Contact closes** the circuit when the set point is exceeded

**Index 2** according to the contact type no. means:

**Contact opens** the circuit when the set point is exceeded

**Index 3** according to the contact type no. means:

When the set value is exceeded, one circuit is opened and one circuit is closed **simultaneously** (change-over contact)

The following applies, as a general rule, to the contact functions of the model 838 <sup>1)</sup> inductive contacts in connection with our standard settings:

**Index 1** according to the contact type no. means:

**Contact closes** the control circuit when the set point is exceeded (flag disengages **from control head**)

**Index 2** according to the contact type no. means:

**Contact opens** the control circuit when the set point is exceeded (flag engages **with control head**)

The switching functions are based on a clockwise rotational motion of the instrument pointer.

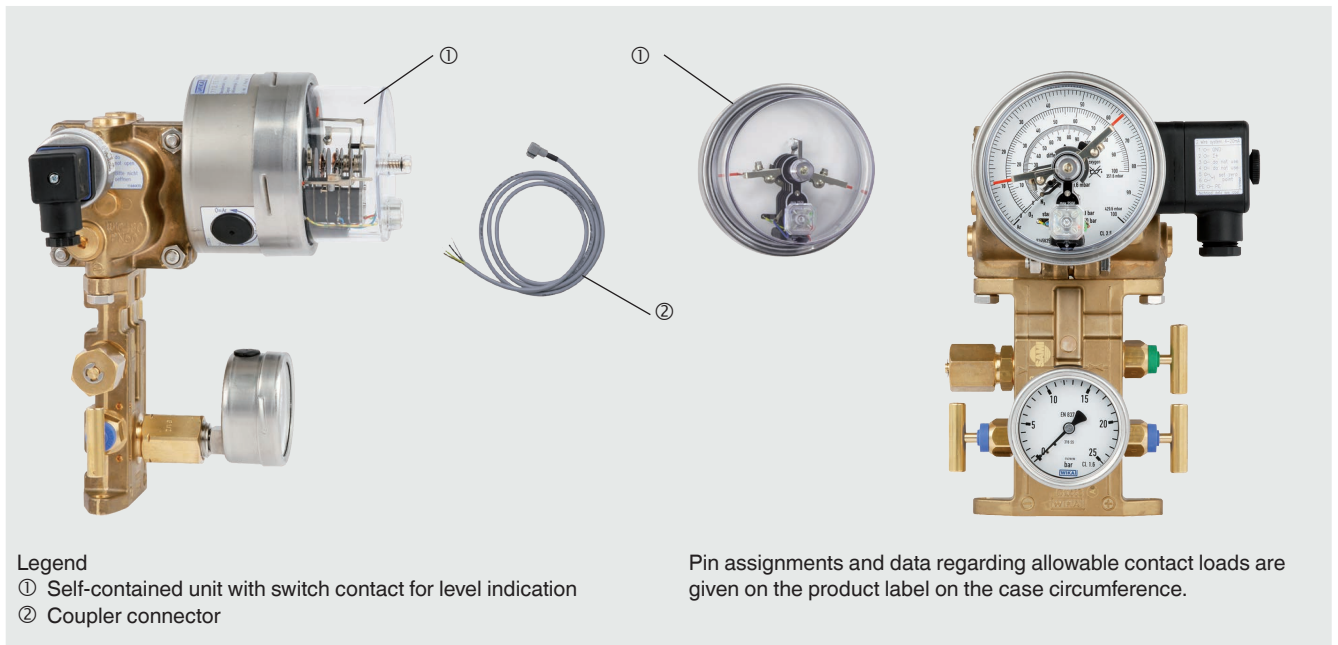

For further specifications and design details see data sheet AC 08.01 <sup>1)</sup>

<sup>1)</sup> Specifications given in data sheet AC 08.01 for Model 821 correspond to model 828 (built into a self-contained unit) Model 831 correspond to model 838 (built into a self-contained unit)

## Dimensions in mm

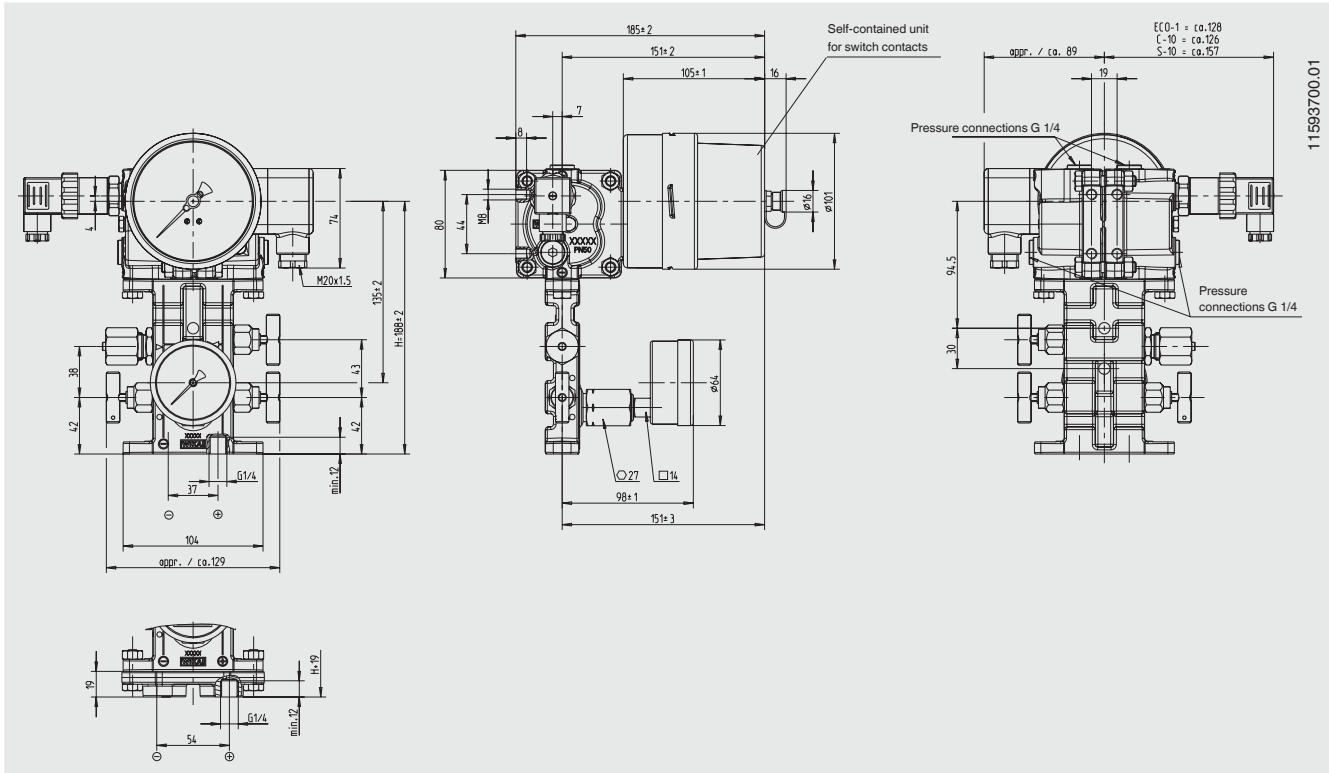

## Option

### Panel mounting

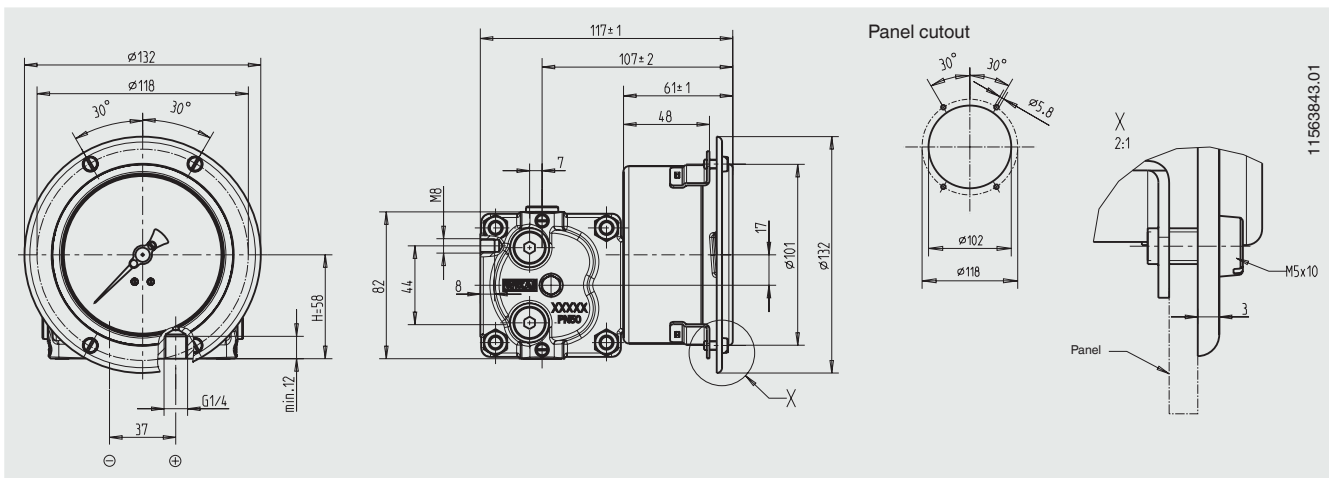

## Ordering information

Model / Scale range (measuring cell) / Scale design / Process connections with centre distance / Options

© 2010 WIKA Alexander Wiegand SE & Co. KG, all rights reserved.  
The specifications given in this document represent the state of engineering at the time of publishing.  
We reserve the right to make modifications to the specifications and materials.

